



Code 1704

HMS II.4

**Head Measurement System with Right Ear Simulator and 3.3 Pinna
(Without Artificial Mouth)**

OVERVIEW

HMS II.4

Code 1704

Head Measurement System with Right Ear Simulator and 3.3 Pinna (Without Artificial Mouth)

HMS II.4 is an artificial head including a right ear simulator. The system is ideally suited for measuring close-to-the-ear transducers in handsets, headsets, headphones, earphones, hearing protectors, and hearing aids. By realistically replicating the acoustically relevant structures of the human anatomy, HMS II.4 also applies to measurements of far-to-the-ear transducers, such as hands-free equipment. It does not apply to measurements requiring speech playback.

The occluded ear simulator complies with IEC 60318-4 and Recommendation ITU-T P.57. The anatomically shaped pinnae are compliant with the type 3.3 pinna simulator according to Recommendation ITU-T P.57 and IEC 60318-7. The low self-noise level allows conclusive measurements close to the hearing threshold. Combined with a very high upper limit, HMS II.4 is ideally suited for all measurements in telecommunication and beyond.

KEY FEATURES

Geometry and acoustical characteristics according to Recommendation ITU-T P.58

Modular design for easy retrofitting with compatible components

Geometry of head and torso simulator according to IEC 60318-7

Ear simulator:

- › Anatomically shaped pinnae for comprehensive measurements in near- and far-field
- › Compliant with occluded ear simulator according to IEC 60318-4
- › Compliant with pinna simulator according to IEC 60318-7
- › Compliant with type 3.3 pinna simulator according to Recommendation ITU-T P.57
- › High quality condenser microphone with low inherent noise floor and very high SPL limit
- › TEDS support (IEEE 1451.4 class MMI)

APPLICATIONS

Recording and measuring signals from headsets and headphones

Listening effort measurements

Testing active and passive hearing protectors

DETAILS

HMS II.4 is an artificial head which is ideally suited for recording measurements in the field of telecommunications under realistic conditions. Complying with the geometric and acoustic characteristics of Recommendation ITU-T P.58, HMS II.4 is appropriate for close-to-the-ear but also arbitrary far-field measurement scenarios. It can be used to test all kinds of transducers in, e.g., headsets, headphones, loudspeakers, hearing protectors, and more.

DESCRIPTION

Ear Simulator and Pinnae

The pinna and the ear simulator of HMS II.4 accurately replicate the anatomy and the performance of the human outer ear. For standard-compliant measurements, the occluded ear simulator complies with IEC 60318-4 and the type 3.3 pinnae comply with Recommendation ITU-T P.57 as well as IEC 60318-7. The built-in microphone capsule provides a low inherent noise floor and has a very high sound pressure level limit. As such, it is qualified for any measurement with signal levels close to the human hearing threshold as well as for measurements with very high levels.

Recording

For recordings, HMS II.4 connects to the ACQUA communication analysis system via the *labCORE* hardware platform equipped with the optional *coreIN-Mic4* hardware board. The *coreBEQ* software extension for *labCORE* provides equalization of binaural acoustical signals for recordings with HMS II.4.

Modularity

The modular design of the artificial ear enables adding or changing ear simulator(s) and pinnae quickly. This facilitates the installation of a left-side ear simulator for binaural measurements. Another advantage is the interchangeability with either the ear simulator of the low-noise variant HIS L LN/HIS R LN (with pinna type 3.3) or the low-noise ear simulator HIS L LN HEC/HIS R LN HEC with a pinna having a human-like ear canal (pinna type 4.4). HMS II.4 includes TEDS (Transducer Electronic Data Sheet) technology that enables ACQUA to determine the type and serial number of the ear simulators, as well as HMS II.4 itself.



HMS II.4 mounted on the HTB VI torso box

Accessories

For measurements of telephony handsets, HMS II.4 is expandable by the optional handset positioners HHP IV or HHP III.1. Both provide precise positioning of any handset as well as precise adjustment of application force from the handset to the pinna.

Another accessory is the AN HMS artificial nose. It makes measurements of nose-supported device, e.g., AR/VR glasses and headsets, more reproducible and convenient to set up.

HMS II.4 has a mounting plate on top for attaching MSA I/MSA II. MSA I/MSA II are microphone surround arrays for recording customized background noises and for an equalized playback via 3PASS. Furthermore, the mounting plate provides fixation for the TLP II triaxial laser pointer for precise alignment of HMS II.4.

The HTB VI torso box simulates a human torso. It is included in the scope of supply by default. HMS II.4 mounted on HTB VI forms a head and torso simulator (HATS) according to Recommendation ITU-T P.58. The bottom plate of HMS II.4 provides a Camlock coupling for convenient mounting on HTB VI.

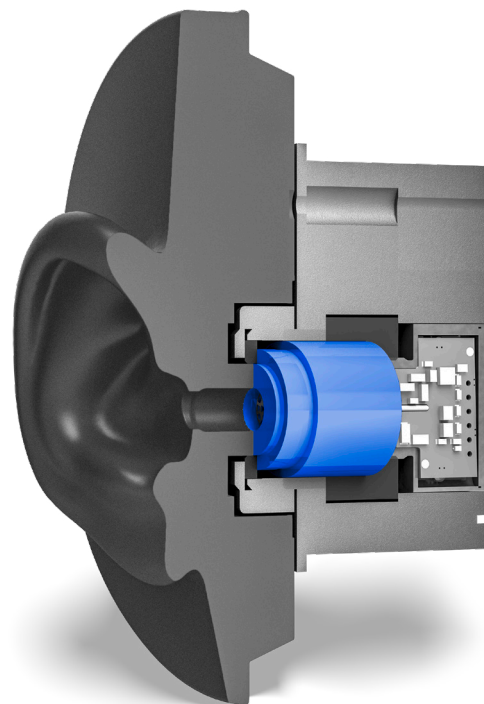

A cut through the right ear simulator of HMS II.4. The straight ear canal leads to the acoustic coupler (highlighted in blue) that contains a high-quality condenser microphone. The microphone covers a very wide dynamic range from close to the human hearing threshold up to 164 dB_{SPL}.

TECHNICAL DATA

Artificial Ear

Frequency range	3 Hz – 20000 Hz
Frequency responses (FF/DF)	Compliant with Recommendation ITU-T P.58
Directivity characteristics	Compliant with Recommendation ITU-T P.58
Transfer impedance	Compliant with IEC 60318-4 and Recommendation ITU-T P.57
Dynamic range	23 dB(A) _{SPL} – 164 dB _{SPL}
Self-noise	Compliant with Recommendation ITU-T P.57
Microphone sensitivity	12.5 mV/Pa
Polarization voltage	200 V
Supply voltages	
› U (recommended)	› ± 60 V
› U (possible)	› + 120 V

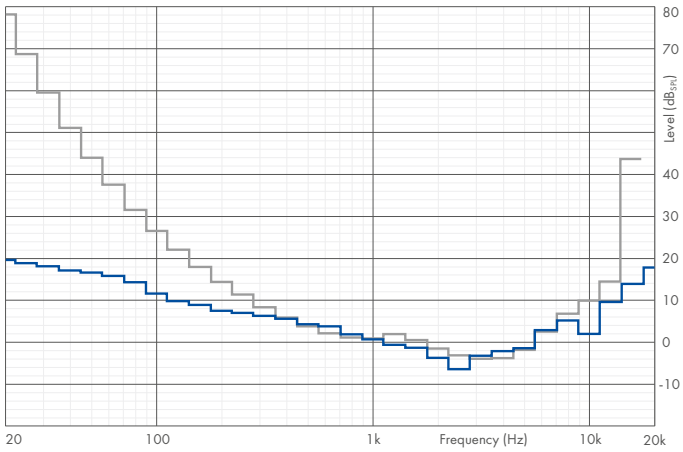

Typical self-noise of HMS ear simulators (—) vs. average human hearing threshold (—)

All curves diffuse-field equalized, HMS II.4 measured with 4096 FFT, average hearing threshold according to ISO 389-7

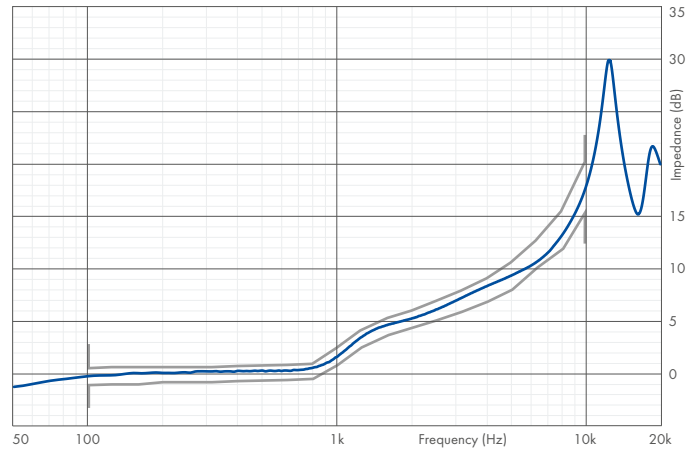

Typical transfer impedance of HMS II.4 ear simulator (—) vs. IEC 60318-4 tolerance scheme (—)

Curve and tolerance scheme normalized to 500 Hz

Other

Dimensions and Weight	
Overall dimensions (Width × Height × Depth)	460 mm × 400 mm × 210 mm 460 mm × 790 mm × 400 mm mounted on HTB VI
Weight	Approx. 5.1 kg (standard scope of delivery) Approx. 13.1 kg mounted on HTB VI
Environmental Conditions	
Operating temperature range	0 °C – 50 °C (32 °F – 122 °F)
Storage temperature range	-20 °C – 70 °C (-4 °F – 158 °F)
Humidity	20% – 80% relative humidity (non-condensing environment)

FEATURES

MSA II

A centrally embedded thread at the top of HMS holds top-mounted accessories such as the MSA II symmetrical microphone array.



ARTIFICIAL NOSE

The optional AN HMS artificial nose can be fixed at the facial crosshair of HMS II.4.



BOTTOM PLATE

The bottom plate provides two 7-pin LEMO connectors for left and right ear simulator.

A quick-clamping mechanism enables easy and fast attaching of HMS II.4 to the HTB VI torso box. The thread below (3/8" UNC) allows to fasten HMS on ,e.g., the optional HMT III tripod.



PINNA AND IMPEDANCE SIMULATOR

The anatomically shaped pinna of HMS II.4 replicates the geometry of a human auricle. Behind the right pinna, the impedance simulator HIS R (shown) simulates the ear's acoustic properties.



EAR SIMULATOR AND PINNA OPTIONS

By default, HMS II.4 has a left and right pinna type 3.3 and a right ear impedance simulator for monaural measurements. It is extendable by a left ear impedance simulator for binaural testing. The modular design of the HMS II Series enables to build numerous different configurations optimized for specific purposes.



HIS L/R LN

- > Low-noise impedance simulator with straight ear canal
- > Anatomically shaped pinna type 3.3 with straight ear canal



HIS L/R LN HEC

- > Low-noise impedance simulator with human-like ear canal
- > Anatomically shaped pinna type 4.4 with human-like ear canal

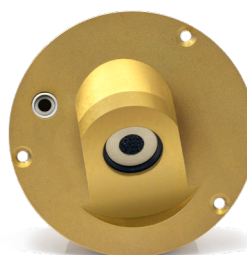

OPTIONS

General

coreBEQ (Code 7740)

- › labCORE binaural equalization, incl. filter set for one artificial head

coreBEQ-Add (Code 7741)

- › labCORE binaural equalization, additional set of filters for one artificial head (coreBEQ required)

AN HMS (Code 1418)

- › Extension for Head Measurement System HMS: Artificial nose

UG HMS/HSU move°S (Code 1750)

- › Upgrade HMS/HSU to move°S, motorized head turning version

HSM V (Code 1520)

- › HEAD Seat Mount adapter for HMS/HSU

HSC V-V2 (Code 1525-V2)

- › Carrying case for HMS II.x

HMT III (Code 1961)

- › Height-adjustable tripod for Head Measurement System

SB HRT (Code 6501)

- › Stand base for mounting HMS II.x on HRT I

TLP II (Code 1969)

- › Triaxial Laser Pointer for HMS/HSU positioning

Ear Simulator Retrofitting

Delivery of left impedance simulators includes the cable LEMO 7-pin male <> LEMO 7-pin male, black, 2.95 m (Code 1721-3)

HIS L (Code 1701)

- › Head impedance simulator, left, for HMS II.3/4/5

HIS L LN (Code 1701.1)

- › Head impedance simulator, left, low-noise version, for HMS II.3/4/5

HIS L LN HEC (Code 1701.2)

- › Head impedance simulator, right, low-noise version, for HMS II.3/4/5, human-like ear canal version

HIS R LN (Code 1702.1)

- › Head impedance simulator, right, low-noise version, for HMS II.3/4/5

SCOPE OF DELIVERY

HMS II.4 (Code 1704)

- › Head Measurement System, with right ear simulator, 3.3 pinna (w/o artificial mouth)

HIS R (Code 1702)

- › Head Impedance Simulator, right, for HMS II.3/4/5

HEL 3.3 (Code 1711)

- › Flexible pinna for HMS II.3/4/5, left ear, according to ITU-T P.57 Type 3.3 and IEC 60318-7

HER 3.3 (Code 1712)

- › Flexible pinna for HMS II.3/4/5, right ear, according to ITU-T P.57 Type 3.3 and IEC 60318-7

CLL-R I.3 (Code 1722-3)

- › Cable LEMO 7-pin male <> LEMO 7-pin male, red, 2.95 m

HTB VI (Code 1574)

- › HEAD Torso Box

HCC-HMS (Code 1741)

- › Carrying case for accessory parts HMS II.x including:
 - › HCA HMS II.x (Code 1733)
 - Microphone calibration adapter for HMS II.3/4, circular
 - › AK HMS II.x (Code 1734)
 - Allen key 2.5 mm for pinna, nose, and impedance simulator mounting of HMS II.x
 - › 3 × socket screw M3 × 6 for assembling HIS types (spare parts)

Manual

HIS R LN HEC (Code 1702.2)

- › Head impedance simulator, right, low-noise version, for HMS II.3/4/5, human-like ear canal version

Pinna Retrofitting

HEL 4.4 (Code 1715)

- › Flexible pinna for HMS II.3/4/5, left ear, according to ITU-T P.57 type 4.4

HER 4.4 (Code 1716)

- › Flexible pinna for HMS II.3/4/5, right ear, according to ITU-T P.57 type 4.4

HEL 4.4-V1 (Code 1715-V1)

- › Flexible pinna for HMS II.3/4/5, left ear, according to ITU-T P.57 type 4.4, gray color

HER 4.4-V1 (Code 1716-V1)

- › Flexible pinna for HMS II.3/4/5, right ear, according to ITU-T P.57 type 4.4, gray color

GENERAL REQUIREMENTS

Hardware

labCORE (Code 7700)

- › Modular multi-channel hardware platform
- coreBUS (Code 7710)
- › labCORE I/O bus mainboard
- coreIN-Mic4 (Code 7730)
- › labCORE microphone input board

Software

One of the following software applications:

ACQUA (Code 6810)

- › Advanced Communication Quality Analysis Software, Full license version

ACQUA Compact (Code 6860)

- › Compact test system

RC-labCORE (Code 6984)

- › Remote configuration software for labCORE

Compatibility of Pinnae and Ear Simulators

Pinna type \ Impedance simulator	HEL 3.3	HER 3.3	HEL 4.4	HER 4.4	HEL 4.4-V1	HER 4.4-V1
HIS L	•					
HIS R		•				
HIS L LN	•					
HIS R LN		•				
HIS L LN HEC			•		•	
HIS R LN HEC				•		•

IN PRACTICE

APPLICATION EXAMPLE

Measurement of an In-Vehicle Loudspeaker System by Using HMS II.4

This test scenario presents assessing the audio playback quality of a multi-channel loudspeaker system in a vehicle. HMS II.4 simulates the driver of the vehicle to test the system's performance at the commonly occupied position. *labCORE* connects to the ear simulators of HMS II.4. The vehicle's head unit (HU) is connected to *labCORE* by Bluetooth®. ACQUA operates in conjunction with *labCORE* to generate, receive, and analyze signals. Assessment of audio quality is performed by the MDAQS (MultiDimensional Audio Quality Score) algorithm. It performs an instrumental assessment of the loudspeaker system's playback quality.

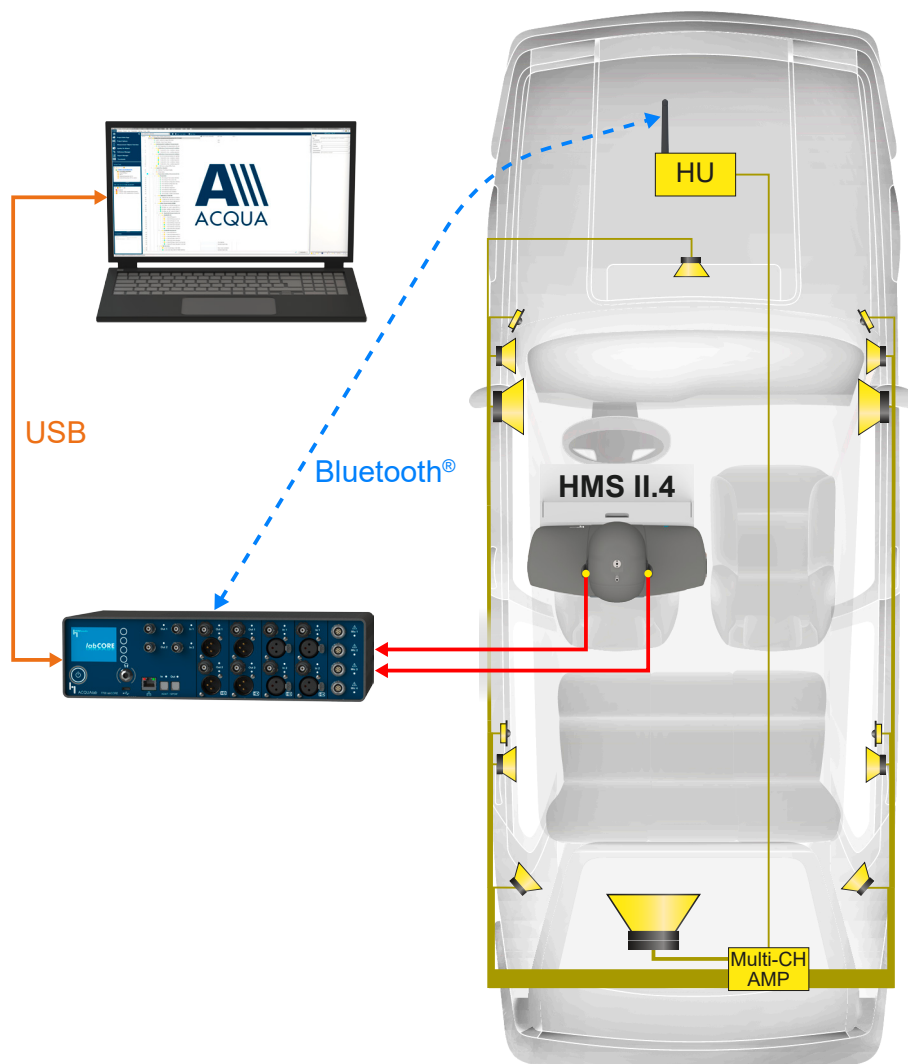

The Bluetooth® word mark and logos are registered trademarks owned by Bluetooth SIG, Inc. and any use of such marks by HEAD acoustics GmbH is under license. Other trademarks and trade names are those of their respective owners.

LEMO® is a registered trademark of LEMO S.A.



Contact Information

Ebertstraße 30a

52134 Herzogenrath, Germany

Phone: +49 2407 577-0

E-Mail: sales@head-acoustics.com

Website: www.head-acoustics.com