



Code 1703.1

HMS II.3 LN

Head Measurement System, Low-Noise Version with Right Ear Simulator, 3.3 Pinna and Artificial Mouth

OVERVIEW

HMS II.3 LN

Code 1703.1

Head Measurement System, Low-Noise Version with Right Ear Simulator, 3.3 Pinna and Artificial Mouth

HMS II.3 LN is an artificial head with an artificial mouth and a low-noise right ear simulator. The system is ideally suited for arbitrary self-noise and distortion measurements of devices close to the ear as well as far-from the ear, particularly at very low sound pressure levels.

The occluded ear simulator is based on IEC 60318-4 and Recommendation ITU-T P.57. The anatomically shaped pinnae are compliant with the type 3.3 pinna simulator according to Recommendation ITU-T P.57 and IEC 60318-7. The very low self-noise level allows conclusive measurements even below the hearing threshold. Combined with a very high upper limit, HMS II.3 LN is ideally suited for all measurements in telecommunication and beyond.

The artificial mouth of HMS II.3 LN has a two-way loudspeaker design and complies with the requirements from Recommendation ITU-T P.58. It is capable of reproducing the full spectrum of human voice with lowest distortion, allowing high-quality measurements.

KEY FEATURES

Geometry and acoustical characteristics according to Recommendation ITU-T P.58

Modular design for easy retrofitting with compatible components

Geometry of head and torso simulator according to IEC 60318-7

Ear simulator:

- › Anatomically shaped pinnae for comprehensive measurements in near- and far-field
- › Based on occluded ear simulator according to IEC 60318-4
- › Compliant with pinna simulator according to IEC 60318-7
- › Compliant with type 3.3 pinna simulator according to Recommendation ITU-T P.57
- › High sensitivity condenser microphone with very low inherent noise floor and high upper limit
- › TEDS support (IEEE 1451.4 class MMI)

Artificial mouth:

- › Low-distortion two-way design with very wide frequency range (up to fullband)
- › Acoustic characteristics according to Recommendation ITU-T P.58
- › Digital equalization with ACQUA

APPLICATIONS

Measurements of:

- › (ANC) Headsets
- › In-vehicle ANC systems
- › Handsets
- › Hands-free devices
- › Hearing aids
- › Voice-operated equipment
- › In-car communication (ICC) devices

DETAILS

HMS II.3 LN is an artificial head which is ideally suited for low-noise measurements in the field of telecommunications under realistic conditions. It comprises an artificial ear as well as an artificial mouth. Complying with the geometric and acoustic characteristics of Recommendation ITU-T P.58, HMS II.3 LN is appropriate for close-to-the-ear but also arbitrary far-field measurement scenarios. It can be used to test transducers and signal processing of, e.g., handsets, headsets, headphones, hands-free devices, voice-operated equipment, hearing protectors, and more.

DESCRIPTION

Ear Simulator and Pinnae

The pinna and the ear simulator of HMS II.3 LN accurately replicate the anatomy and the performance of the human outer ear. For standard-compliant measurements, the occluded ear simulator meets the acoustic requirements from IEC 60318-4 and the type 3.3 pinnae comply with Recommendation ITU-T P.57 as well as IEC 60318-7. The built-in microphone capsule provides a very low inherent noise floor and has a high sound pressure level limit. As such, it is qualified for any measurement with signal levels below the human hearing threshold as well as for measurements with high levels.

Artificial Mouth

The artificial mouth of HMS II.3 LN is fully compliant with Recommendation ITU-T P.58. It realistically reproduces the acoustic behavior of a talking person. The two-way loudspeaker design provides an excellent frequency response. The wide frequency range makes it ideally suited for measurements in super-wideband and fullband applications. The artificial mouth is optimized for use with the optional *coreOUT-Amp2* hardware board from the *labCORE* hardware platform.

Playback and Recording

For recordings, HMS II.3 LN connects to the ACQUA communication analysis system via the *labCORE* hardware platform equipped with the optional *coreIN-Mic4* hardware board. The *coreBEQ* software extension for *labCORE* provides equalization of binaural acoustical signals for recordings with HMS II.3 LN.



HMS II.3 LN mounted on the HTB VI torso box

The artificial mouth of HMS II.3 LN is powered by the optional coreOUT-Amp2 hardware board from labCORE. ACQUA supports comfortable and precise equalization of the mouth.

Modularity

The modular design of the artificial ear enables adding or changing ear simulator(s) and pinnae quickly. This facilitates the installation of a left-side ear simulator for binaural measurements. Another advantage is the interchangeability with either the ear simulator of the standard variant HMS II.3 (with pinna type 3.3) or the low-noise ear simulator with a pinna having a human-like ear canal of HMS II.3 LN HEC (with pinna type 4.4). HMS II.3 LN includes TEDS (Transducer Electronic Data Sheet) technology that enables ACQUA to determine the type and serial number of the ear simulators, as well as HMS II.3 LN itself.

Accessories

For measurements of telephony handsets, HMS II.3 LN is expandable by the optional handset positioners HHP IV or HHP III.1. Both provide precise positioning of any handset as well as precise adjustment of application force from the handset to the pinna.

Another accessory is the AN HMS artificial nose. It makes measurements of nose-supported device, e.g., AR/VR glasses and headsets, more reproducible and convenient to set up.

HMS II.3 LN has a mounting plate on top for attaching MSA I/MSA II. MSA I/MSA II are microphone surround arrays for recording customized background noises and for an equalized playback via 3PASS. Furthermore, the mounting plate provides fixation for the TLP II triaxial laser pointer for precise alignment of HMS II.3 LN.

The HTB VI torso box simulates a human torso. It is included in the scope of supply by default. HMS II.3 LN mounted on HTB VI forms a head and torso simulator (HATS) according to Recommendation ITU-T P.58. The bottom plate of HMS II.3 LN provides a Camlock coupling for convenient mounting on HTB VI.

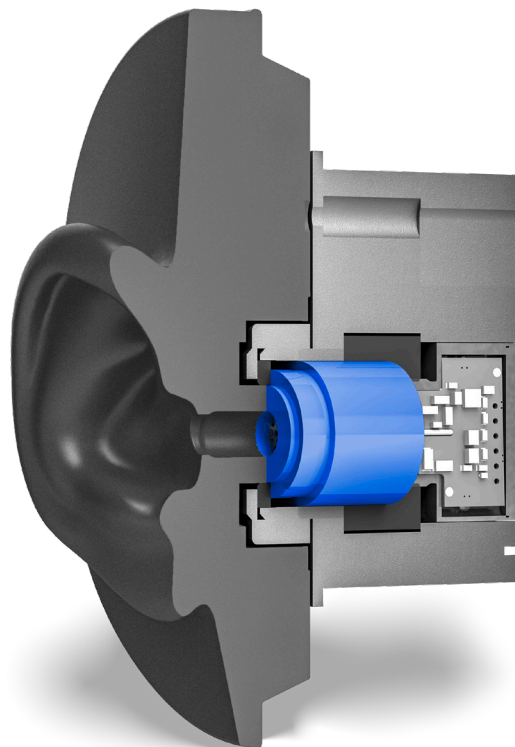

A cut through the right ear simulator of HMS II.3 LN. The straight ear canal leads to the acoustic coupler (highlighted in blue) that contains a high-quality condenser microphone. The microphone covers a very wide dynamic range from below the human hearing threshold up to 148 dB_{SPL}.

TECHNICAL DATA

Artificial Ear

| | |
|-----------------------------|--|
| Frequency range | 3 Hz – 20000 Hz |
| Frequency responses (FF/DF) | Compliant with ITU-T Recommendation P.58 |
| Directivity characteristics | Compliant with ITU-T Recommendation P.58 |
| Transfer impedance | Compliant with IEC 60318-4 and Recommendation ITU-T P.57 |
| Dynamic range | 16 dB(A) _{SPL} – 148 dB _{SPL} |
| Self-noise | Compliant with Recommendation ITU-T P.57 |
| Microphone sensitivity | 50 mV/Pa |
| Polarization voltage | 200 V |
| Supply voltages | |
| › U (recommended) | › ± 60 V |
| › U (possible) | › + 120 V |

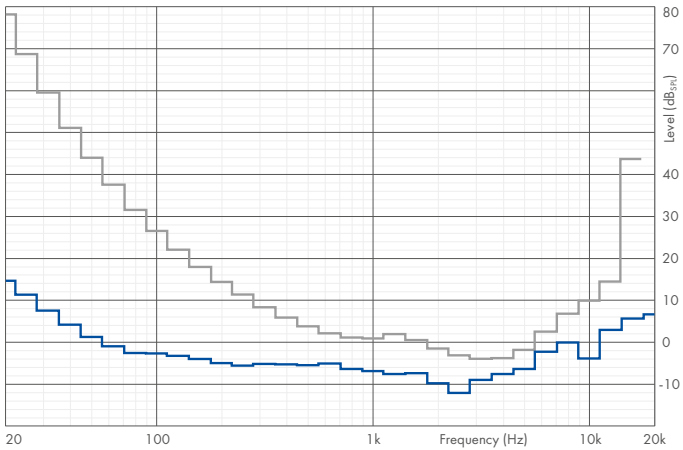

Typical self-noise of HMS II.3 LN ear simulators (—) vs. average human hearing threshold (---)

All curves diffuse-field equalized, HMS II.3 LN measured with 4096 FFT, average hearing threshold according to ISO 389-7

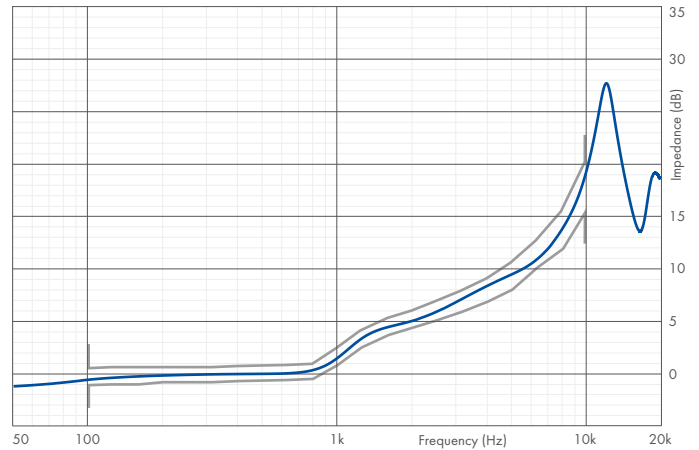

Typical transfer impedance of HMS II.3 LN ear simulator (—) vs. ITU-T P.57 tolerance scheme (---)

Curve and tolerance scheme normalized to 500 Hz

Artificial Mouth

| | |
|---------------------------------|--|
| Loudspeaker configuration | 2-way |
| Impedance | 4 Ω |
| Frequency range | <ul style="list-style-type: none"> › Unequalized › Equalized |
| Power handling | <ul style="list-style-type: none"> › P (continuous) › P (short-term) |
| Total Harmonic Distortion (THD) | <ul style="list-style-type: none"> › at 0 dB_{Pa} (94 dB_{SPL}) › at 6 dB_{Pa} (100 dB_{SPL}) › at 12 dB_{Pa} (106 dB_{SPL}) › at 18 dB_{Pa} (112 dB_{SPL}) |
| Max. continuous output level | <ul style="list-style-type: none"> › Pink noise › Sine › Real speech according to Recommendation ITU-T P.501 |
| | <p>at Mouth reference Point (MRP), equalized, with coreOUT-Amp2</p> <ul style="list-style-type: none"> › 100 Hz – 20000 Hz (± 4 dB) › 50 Hz – 20000 Hz (± 1 dB), exceeds ETSI TS 102 924 › 20 W › 50 W (max. power is electrically limited > 6 kHz) › at MRP, equalized, with coreOUT-Amp2 › < 4% (100 Hz), < 0.5% (200 Hz – 20000 Hz), exceeds Recommendation ITU-T P.58 › < 6% (100 Hz), < 1% (200 Hz – 20000 Hz) › < 10% (100 Hz), < 2% (200 Hz – 20000 Hz) › < 3% (200 Hz – 20000 Hz) › min. 112 dB_{SPL} (50 Hz – 16000 Hz), min. 106 dB_{SPL} (20 Hz – 20000 Hz) › min. 112 dB_{SPL} (200 Hz – 6000 Hz) at THD < 3%, min. 106 dB_{SPL} (100 Hz – 10000 Hz) at THD < 10% › No audible distortion up to approx. 110 dB_{SPL} |

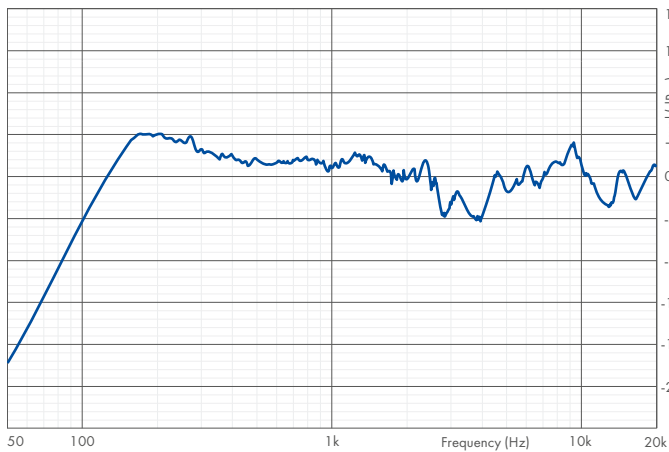

Typical frequency response of unequalized two-way mouth (—)

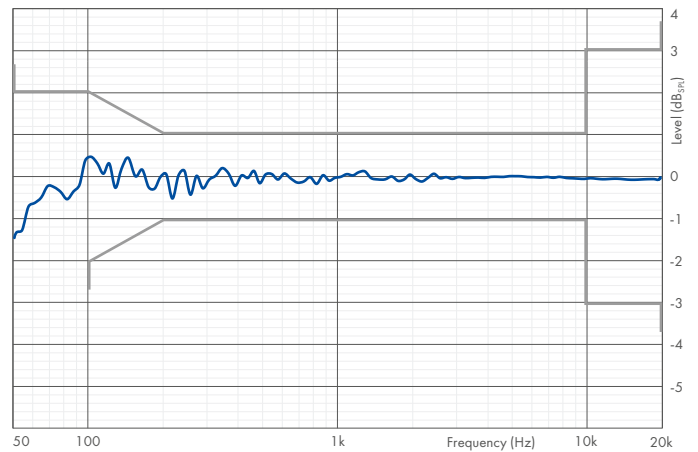

Typical frequency response of equalized two-way mouth (—) vs. ETSI TS 102 924 tolerance scheme (—)

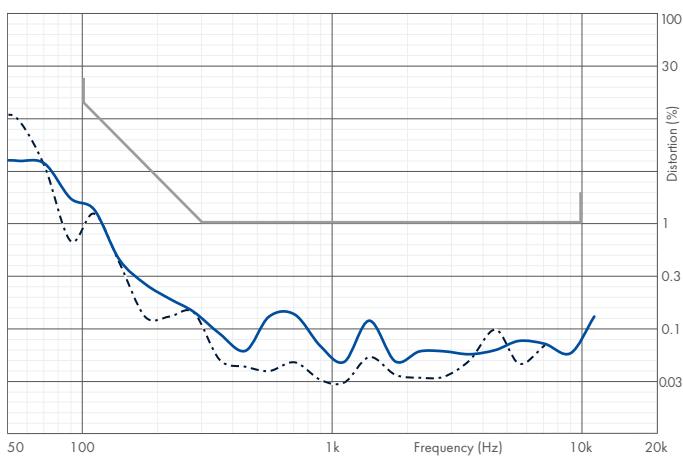

2nd (—) and 3rd (---) order harmonic distortion of equalized two-way mouth at 0 dB_{po} vs. Recommendation ITU-T P.58 tolerance scheme (—)

Other

| Dimensions and Weight | |
|--|--|
| Overall dimensions (Width × Height × Depth) | 460 mm × 400 mm × 210 mm 460 mm × 790 mm × 400 mm mounted on HTB VI |
| Weight | Approx. 6.1 kg (standard scope of delivery) Approx. 14.1 kg mounted on HTB VI |
| Environmental Conditions | |
| Operating temperature range | 0 °C – 50 °C (32 °F – 122 °F) |
| Storage temperature range | -20 °C – 70 °C (-4 °F – 158 °F) |
| Humidity | 20% – 80% relative humidity (non-condensing environment) |

FEATURES

MSA I/MSA II

A centrally embedded thread at the top of HMS holds top-mounted accessories such as the microphone arrays MSA I, MSA II (shown), or the Triaxial Laser Pointer TLP II.



IMPEDANCE SIMULATOR AND PINNA

The anatomically shaped pinna of HMS II.3 LN replicates the geometry of a human auricle. Behind the pinna, the impedance simulator HIS R LN (shown) simulates the ear's acoustic properties.



HANDSET POSITIONER

Four neck bolts provide sturdy mounting points for an optional handset positioner. Available devices are the manual HHP III.1 or the motorized HHP IV (shown).



ARTIFICIAL MOUTH AND ARTIFICIAL NOSE

The two-way loudspeaker design of the artificial mouth provides excellent frequency coverage, a high maximum SPL, and very low distortion.

The optional AN HMS artificial nose can be fixed at the facial crosshair of HMS II.3 LN.



BOTTOM PLATE

The bottom plate provides a speakON connector for the artificial mouth and two 7-pin LEMO connectors for left and right ear simulator.

A quick-clamping mechanism enables easy and fast attaching of HMS II.3 LN to the HTB VI torso box. The thread below allows to fasten HMS on, e.g., the optional HMT III tripod.



MICROPHONE HOLDER

A snap lock at the throat can accommodate the delivered microphone mount for calibration of the mouth. Durable rubber rings can accommodate optional microphones of different sizes.

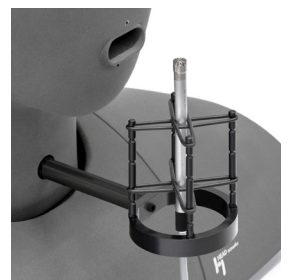

EAR SIMULATOR AND PINNA OPTIONS

By default, HMS II.3 LN has a left and right pinna type 3.3 and a right ear impedance simulator for monaural measurements. It is extendable by a left ear impedance simulator for binaural testing. The modular design of the HMS II Series enables to build numerous different configurations optimized for specific purposes.



HMS II.3

- › Impedance simulator with straight ear canal
- › Anatomically shaped pinna type 3.3 with straight ear canal



HMS II.3 LN HEC

- › Low-noise impedance simulator with human-like ear canal
- › Anatomically shaped pinna type 4.4 with human-like ear canal

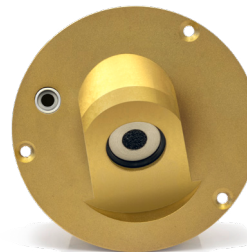

HMS II.3 ViBRIDGE

- › Low-noise impedance simulator with human-like ear canal
- › Anatomically shaped pinna type 4.4 with human-like ear canal and bone conduction simulation

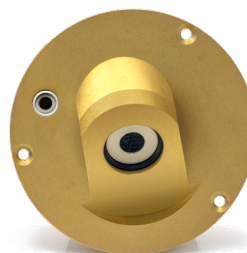

FURTHER HMS II MODELS

Further specific versions of the HMS II Series are available.

HMS II.4

- › Anatomically shaped pinnae type 3.3
- › Right ear impedance simulator
- › Ear retrofitting options
- › No artificial mouth (not retrofittable)



HMS II.5

- › Anatomically shaped pinnae type 3.3
- › No impedance simulators
- › Ear retrofitting options
- › Artificial mouth



HMS II.6/7

- › Left and right free-field microphones and impedance converter
- › Simplified pinnae
- › HMS II.6 has condenser microphones
- › HMS II.7 has IEPE/ICP® microphones
- › Artificial mouth



OPTIONS

General

coreBEQ (Code 7740)

- › labCORE binaural equalization, incl. filter set for one artificial head

coreBEQ-Add (Code 7741)

- › labCORE binaural equalization, additional set of filters for one artificial head (coreBEQ required)

SCOPE OF DELIVERY

HMS II.3 LN (Code 1703.1)

- › Head Measurement System, low-noise version with right ear simulator, 3.3 pinna and artificial mouth
- HIS R LN (Code 1702.1)
- › Head Impedance Simulator, right, low-noise version, for HMS II.3/4/5

HEL 3.3 (Code 1711)

- › Flexible pinna for HMS II.3/4/5, left ear, according to ITU-T P.57 type 3.3 and IEC 60318-7
- HER 3.3 (Code 1712)
- › Flexible pinna for HMS II.3/4/5, right ear, according to ITU-T P.57 type 3.3 and IEC 60318-7
- CLL-R I.3 (Code 1722-3)
- › Cable LEMO 7-pin male <> LEMO 7-pin male, red, 2.95 m

CSS V.3 (Code 1723-3)

- › Cable speakON plug <> speakON plug, 2.95 m
- CSB II (Code 9849)

- › Adapter speakON male <> Banana plug
- HTB VI (Code 1574)

- › HEAD Torso Box for HMS and HSU
- HCC-HMS (Code 1741)

- › Carrying case for accessory parts HMS II.x containing:

- › Mic-pos (Code 1731)
 - Microphone positioner for HMS II.3/5/6/7
- › LR-MRP (Code 1626)
 - Lip ring and MRP pointer
- › HCA HMS II.x (Code 1733)
 - Microphone calibration adapter for HMS II.3/4, circular
- › AK HMS II.x (Code 1734)
 - Allen key 2.5 mm for pinna, nose, and impedance simulator mounting of HMS II.x
- › 3 × socket screw M3 × 6 for assembling HIS types (spare parts)
- › 2 × Throat blind cap (spare parts)

Manual

AN HMS (Code 1418)

- › Extension for Head Measurement System HMS: Artificial nose

UG HMS/HSU move°S (Code 1750)

- › Upgrade HMS/HSU to move°S, motorized head turning version

HSM V (Code 1520)

- › HEAD Seat Mount adapter for artificial head measurement systems or a head-shoulder unit

HSC V-V2 (Code 1525-V2)

- › Carrying case for HMS II.x

HMT III (Code 1961)

- › Height-adjustable tripod for Head Measurement System

SB HRT (Code 6501)

- › Stand base for mounting HMS II.x on HRT I

TLP II (Code 1969)

- › Triaxial Laser Pointer for HMS/HSU positioning

Ear Simulator Retrofitting

Delivery of left impedance simulators includes the cable LEMO 7-pin male <> LEMO 7-pin male, black, 2.95 m (Code 1721-3)

HIS L LN (Code 1701.1)

- › Head Impedance Simulator, left, low-noise version, for HMS II.3/4/5

HIS L (Code 1701)

- › Head Impedance Simulator, left, for HMS II.3/4/5

HIS L LN HEC (Code 1701.2)

- › Head Impedance Simulator, left, low-noise, for HMS II.3/4/5, human ear canal version

HIS R (Code 1702)

- › Head Impedance Simulator, right, for HMS II.3/4/5

HIS R LN HEC (Code 1702.2)

- › Head Impedance Simulator, right, low-noise, for HMS II.3/4/5, human ear canal version

GENERAL REQUIREMENTS

Hardware

*lab*CORE (Code 7700)

- › Modular multi-channel hardware platform
- core*BUS (Code 7710)
- › *lab*CORE I/O bus mainboard
- core*OUT-Amp2 (Code 7720)
- › *lab*CORE power amplifier board
- core*IN-Mic4 (Code 7730)
- › *lab*CORE microphone input board

Software

One of the following software applications:

ACQUA (Code 6810)

- › Advanced Communication Quality Analysis Software, Full license version

ACQUA Compact (Code 6860)

- › Compact test system

RC-*lab*CORE (Code 6984)

- › Remote configuration software for *lab*CORE

VoCAS (Code 7970)

- › Voice Control Analysis System

Pinna Retrofitting

HEL 4.4 (Code 1715)

- › Flexible pinna for HMS II.3/4/5, left ear, according to ITU-T P.57 type 4.4

HER 4.4 (Code 1716)

- › Flexible pinna for HMS II.3/4/5, right ear, according to ITU-T P.57 type 4.4

HEL 4.4-V1 (Code 1715-V1)

- › Flexible pinna for HMS II.3/4/5, left ear, according to ITU-T P.57 type 4.4, gray color

HER 4.4-V1 (Code 1716-V1)

- › Flexible pinna for HMS II.3/4/5, right ear, according to ITU-T P.57 type 4.4, gray color

HEL 4.4 ViBRIDGE (Code 1717)

- › Flexible pinna for HMS II.3/5, left ear, according to ITU-T P.57 type 4.4, ViBRIDGE version

HER 4.4 ViBRIDGE (Code 1718)

- › Flexible pinna for HMS II.3/5, right ear, according to ITU-T P.57 type 4.4, ViBRIDGE version

HEL 4.4 ViBRIDGE-V1 (Code 1717-V1)

- › Flexible pinna for HMS II.3/5, left ear, gray color, according to ITU-T P.57 type 4.4, ViBRIDGE version

HER 4.4 ViBRIDGE-V1 (Code 1718-V1)

- › Flexible pinna for HMS II.3/5, right ear, gray color, according to ITU-T P.57 type 4.4, ViBRIDGE version

Compatibility of Pinnae and Ear Simulators

| Pinna type \ Impedance simulator | HEL 3.3 | HER 3.3 | HEL 4.4 | HER 4.4 | HEL 4.4-V1 | HER 4.4-V1 | HEL 4.4 ViBRIDGE | HER 4.4 ViBRIDGE | HEL 4.4 ViBRIDGE-V1 | HER 4.4 ViBRIDGE-V1 |
|----------------------------------|---------|---------|---------|---------|------------|------------|------------------|------------------|---------------------|---------------------|
| HIS L | • | | | | | | | | | |
| HIS R | | • | | | | | | | | |
| HIS L LN | • | | | | | | | | | |
| HIS R LN | | • | | | | | | | | |
| HIS L LN HEC | | | • | | • | | • | | • | |
| HIS R LN HEC | | | | • | | • | | • | | • |

IN PRACTICE

APPLICATION EXAMPLE

Measurement of an In-Vehicle Active Noise Cancellation (ANC) System

Beforehand, background noise has been recorded at the vehicles microphones via A²B and binaurally at the ANC zone. The A²B bus of the vehicle is connected to *coreA2B* at *labCORE*. *coreA2B* is in proxy mode and connects between main and the first subordinate node. ANC functionality is activated in the vehicle. ACQUA injects the background noise recordings electrically into the live measurements. Therefore, the ANC system generates the phase-reversed anti-noise according to the detected background noise signals. Simultaneously, HMS II.5 plays back speech signals. HMS II.3 LN records the speech signals under influence of the phase-reversed anti-noise signal from the ANC system. ACQUA injects the binaural recording including background noise via *labCORE* to the binaural live recording from HMS II.3 LN. *labCORE* transmits the combined signal to ACQUA for analyzing.

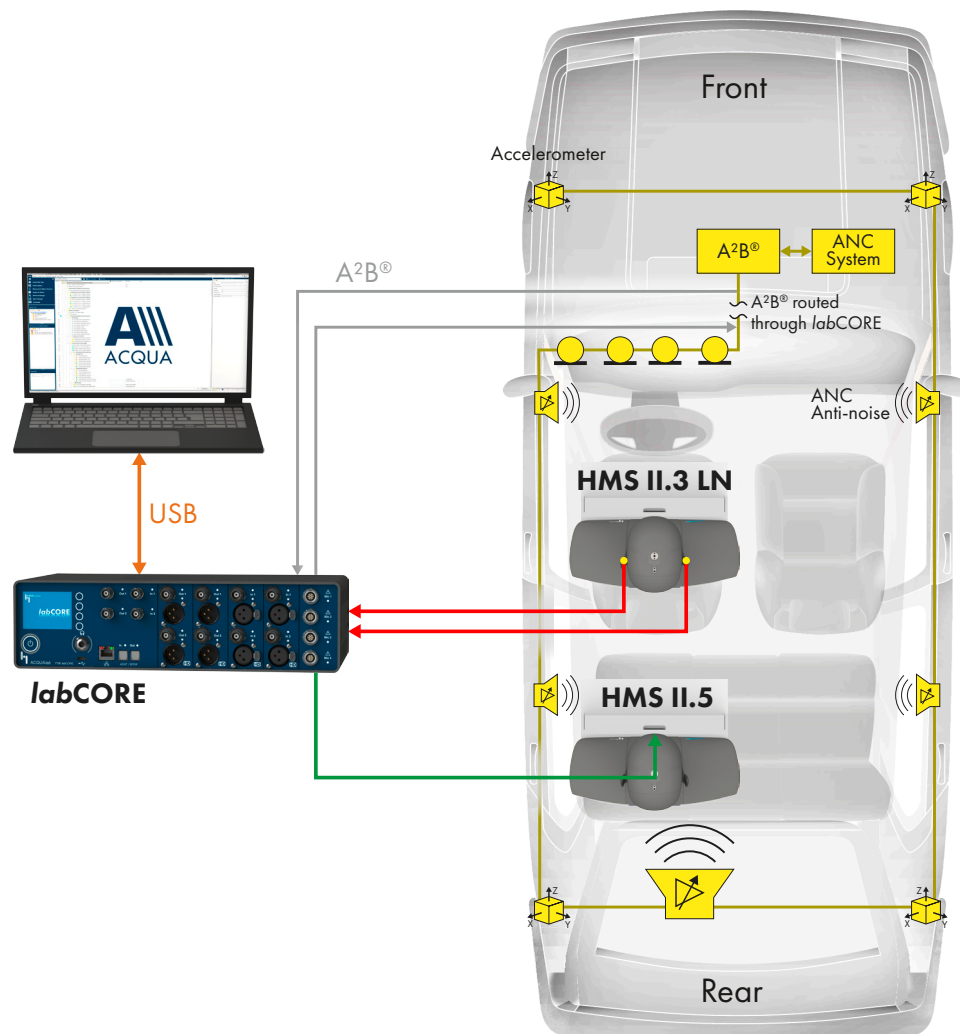

ICP® is a registered trademark of PCB Group, Inc.

speakON® is a registered trademark of Neutrik AG.

LEMO® is a registered trademark of LEMO S.A.

Automotive Audio Bus® (A2B®) is a trademark of Analog Devices, Inc.

IEPE denotes an industry standard for piezoelectric sensors with integrated impedance-converting electronics. Comparable technologies are marketed by individual manufacturers under proprietary names such as ICP, CCLD, IsoTron, or DeltaTron. In this document, the term IEPE/ICP is used as a generic designation representing the corresponding manufacturer-specific product and trademark names.



Contact Information

Ebertstraße 30a

52134 Herzogenrath, Germany

Phone: +49 2407 577-0

E-Mail: sales@head-acoustics.com

Website: www.head-acoustics.com