



Code 60026

MS Teams

Measurements and Analyses According to Microsoft Teams Audio Test Specification

OVERVIEW

MS Teams

Code 60026

Measurements and Analyses According to Microsoft Teams Audio Test Specification

Microsoft Teams is a versatile platform for collaboration and communication at the workplace as well as the home office. Good speech quality is a key factor, making communication via Teams effortless and smooth.

Microsoft defined performance requirements for respective communication devices and accessories in the Microsoft Teams Audio Test Specification V5.0 including Addendum A to ensure optimal speech quality in conversations held via Teams. The document specifies tests to assess communication devices focused on usability-oriented characteristics such as speech quality, signal-to-noise ratio, echo, and delay.

HEAD acoustics implemented all tests laid out in the specification in the automated test suite MS Teams for ACQUA. It allows efficient automated testing of suitable devices for compliance with the Microsoft Teams Audio Test Specification V5.0 including Addendum A.

KEY FEATURES

Comprehensive automated test suite for measurement and evaluation of communication devices for Microsoft Teams

Support of all device types laid out in the Microsoft Teams Audio Test Specification V5.0 including Addendum A

Automated and fully repeatable tests with realistic background noise simulation, device rotation, and echo path variation

APPLICATIONS

Automated quality analysis, evaluation, and comparison of communication devices in compliance with the Microsoft Teams Audio Test Specification V5.0 including Addendum A



The 'Certified for Microsoft Teams' logo displayed on e.g., retail packaging to indicate that the product has been certified for use with Microsoft teams as laid out by Microsoft.

DETAILS

The IP-based audio and video communication service Microsoft Teams is used for communicating with people all around the world. Its frequent use in office environments sets special focus on good communication quality. Effortless communication ensures efficient interaction and promotes a pleasant working environment. Language barriers are easier to overcome, the need for frequent repetition and clarification due to poor intelligibility is avoided. Offering good communication quality also conveys a professional company image.

For ensuring a high standard of communication quality when using Teams, Microsoft issues the Microsoft Teams Audio Test Specification. The document defines requirements for devices used in office environments with the telecommunication software Microsoft Teams.

Devices that meet all requirements laid out in the test specification are eligible for the Microsoft Teams hardware certification process. The associated certification logo on the sales packaging makes customers aware that the device is ideally qualified for audio communication with Microsoft Teams.

Device Types and Connectivity

The Microsoft Teams Audio Test Specification including Addendum A describes test methods for communication devices typically used with Microsoft Teams:

- › Headsets
- › Personal space desk phones
- › Personal space speakerphones
- › Shared space speakerphones

For each device type, the specification defines setups simulating typical real-life applications. As such, devices that are typically used in various configurations, e.g. shared space speakerphone systems with multiple units, are described with a correspondingly large number of test scenarios.

Typical connection types for PC-dependent communication devices used with Microsoft Teams are USB and Bluetooth®. In detail however, these connection types branch into different versions. For example, some devices providing a USB interface are delivered with an USB-dongle to connect wirelessly. The

wireless transmission may use other technologies (e.g., Bluetooth), but Microsoft Teams client PC recognizes a USB connection. A standalone, fully PC-independent variant are desk phones and personal/shared space speakerphones with an embedded Teams client running on the device itself.

Aspects of Speech Quality

For all these devices and connection types, the test specification covers all relevant speech quality aspects in sending and receiving direction, sidetone (if applicable), and echo performance, as well as speech quality in presence of background noise and during double talk.



The tests are based on Microsoft's expertise with Teams devices and on proven standards such as ITU-T P.502, ETSI TS 103 106, and more.

For test results, the specification differentiates between standard and premium requirements. Devices shall meet the standard requirements for achieving a Microsoft Teams Hardware Certification. Premium requirements are set as an optional design target for manufacturers to achieve very high audio quality.

The database also comprises a number of optional tests grouped in individual modules. Headsets can be tested for performance in an open office environment – open office spaces typically contain more distractors and general office background noise – as well as for super-wideband calling capabilities. Passing one or both of these optional test modules is a requirement for being listed under the respective category on Microsoft web pages. For speakerphones, optional test modules are available for positional audio in modern multi-purpose meeting rooms (described by Microsoft as Enhanced Microsoft Teams Rooms or short EMTR) as well as for stereo calling.

Microsoft Teams usually employs the device's natively integrated facilities for voice communication e.g., in smartphones, tablets, laptops, all-in-ones. External devices such as speakerphones most often connect to a Teams client computer by USB or Bluetooth. For such devices (i.e., PC accessories), the specification describes two test methods: firstly setups as they appear in real life – connected to a Microsoft Teams client PC for an end-to-end (E2E) signal flow – and secondly a 'device direct' connection to *labCORE*, allowing extensive testing of the device's raw performance.

Implementation

HEAD acoustics implemented all tests contained in the Test Specification in the automated HEAD acoustics test suite MS Teams. In combination with the necessary hardware and software, the test suite allows automated analysis of any suitable communication device.

The test suite is structured in three main groups of devices. The first group comprises handsets, the second group all types of headsets. The third group aggregates all hands-free applications, namely speakerphones of all types. Independent of type, any device is tested in two environments. The first group of tests is performed in an anechoic room to assess the performance in send and receive direction as well as for the sidetone (if applicable) and echo path, all in the absence of acoustic reflections. Where applicable, type-specific tests are performed as well.

Afterwards, devices are tested in a reverberant room. The specification gives details of the room's characteristic to test any device in a close-to-life environment. Again, the performance of the send

PSMM Skype Positioning Stand

Several measurements in the 'Microsoft Teams Audio Test Specification' require a free-field microphone as well as an artificial mouth. Both shall be set up at defined positions in respect to the device under test. The PSMM Skype positioning stand provides fixation for microphone and artificial mouth. It comprises a sturdy height-adjustable tripod and a horizontal bar with a fixation device. A counterweight balances the bar for use with heavy equipment. For accurate alignment, PSMM Skype is delivered with a laser pointer.



and receive direction and the echo path is tested. Situation-specific tests e.g., with a speech distractor, are also part of this group.

Core elements of any test setup are *labCORE*, ACQUA, a suitable artificial head, as well as background noise simulation by either 3PASS *lab* or HAE-BGN. Two computers run Teams clients – one is a Microsoft Teams reference client (with the DSB IV.1 Digital Sound Board for audio connectivity to *labCORE*), the other one is a client for the device under test (DUT). An exception to the latter are devices with an embedded Teams client, waiving the need for a DUT client PC.

Additionally required hardware and software depends on the individual use case. For any setup, there is equipment for full automation. The MS Teams database contains control information to automatically operate the motorized turntable HRT I (orientation-dependent measurements), the motorized rotating reflector HRR I (variable echo-path), and the motorized handset positioner HHP IV during the respective test runs.

Using MS Teams test suite ensures that devices fulfill requirements from the audio test specification for Microsoft Teams. Therefore, the test suite is ideally suited for fast and convenient testing, comparison, and optimization of qualified devices by manufacturers.

Measurements in MS Teams Database – Handsets and Headsets

SMD name	Handset	Headset
Latency over E2E call	Send and receive	Send and receive
Average speech quality MOS-LQO	Send and receive	Send and receive ¹
Signal level with normal speech	Send	Send ¹
Signal level with quiet speech	Send	Send
Output level at nominal volume	Receive	Receive (monaural and binaural) ¹
Output level at maximum volume	Receive	Receive
Idle and active channel SpNR	Send	Send ¹
SpNR with maximum microphone gain	Send	Send
Idle channel noise	Receive	Receive ¹
Single frequency interference	Send and receive	Send and receive ¹
Activation level in send direction	•	•
Frequency response	Send and receive	Send and receive ¹
No extra gain for quiet signals	Receive	Receive
Terminal coupling loss (TCL)	•	•
EQUEST (Echo MOS) nominal volume	•	• ¹
EQUEST (Echo MOS) maximum volume	•	•
Echo during alternating SND-RCV activity, nominal volume	•	• ¹
Echo during alternating SND-RCV activity, maximum volume	•	•
Send signal attenuation during double talk (Speech-based Double Talk), nominal/maximum volume	•	•
AEC convergence time at call start	•	•
Sidetone masking rating (STMR)	•	•
Sidetone latency	•	•
3QUEST S-/N-MOS (various background noise types)	•	• ²
Device direct latency (wired, wireless)	–	Send and receive
Device direct signal level (normal speech)	–	Send ¹
Device direct signal level (quiet speech)	–	Send
Device direct output level	–	Receive ¹ (monaural and binaural)
Device direct activation level in send direction	–	• ²
Device direct terminal coupling loss (TCL)	–	•
Device direct EQUEST (Echo MOS) nominal volume	–	• ¹
Device direct send signal attenuation during double talk (Speech-based Double Talk), nominal/maximum volume	–	•
Distractor attenuation (average and minimum)	–	Optional module Open Office Headset

- Included
- Not included

¹ Additional for optional module Super-Wideband.

² Additional for optional module Open Office Headset.

Measurements in MS Teams Database – Personal and Shared Space Speakerphone

SMD name	Personal speaker-phone	Shared space speaker-phone
Latency over E2E call	Send and receive	Send and receive
Average speech quality MOS-LQO	Send and receive; Additional for optional module stereo call: Receive stereo left/right and stereo summed to mono	Send and receive
Signal level with normal speech	Send	Send
Signal level with quiet speech	Send	Send
Output level at nominal volume	Receive	Receive
Output level at maximum volume	Receive	Receive
Idle and active channel SpNR	Send	Send
SpNR with maximum microphone gain	Send	Send
Idle channel noise	Receive	Receive
Single Frequency Interference	Send and receive	Send and receive
Signal to distortion and noise ratio (SDNR)	Send and receive	Send and receive
Activation level in send direction	•	•
Frequency response	Send and receive	Send and receive
No extra gain for quiet signals	Receive	Receive
Terminal coupling loss (TCL)	•	•
EQUEST (Echo MOS) nominal volume	•	•
EQUEST (Echo MOS) maximum volume	•	•
Echo during alternating SND-RCV activity, nominal volume	•	•
Echo during alternating SND-RCV activity, maximum volume	•	•
Send signal attenuation during double talk (Speech-based Double Talk), nominal/maximum volume	•	•
AEC convergence time at call start	•	•
Stability loss with variable echo path	•	•
3QUEST S-/N-MOS (various background noise types)	•	•
Speech quality for alternating near end talkers	–	•
Speech level for alternating near end talkers	–	•
Device direct latency (wired, wireless)	Send and receive	Send and receive
Device direct signal level (normal/quiet speech)	Send	Send
Device direct activation level in send direction	•	•
Device direct terminal coupling loss (TCL)	•	•
Device direct EQUEST (Echo MOS) nominal volume	•	•
Device direct send signal attenuation during double talk (Speech-based Double Talk), nominal/maximum volume	•	•
Level versus time speech directivity with single talker	Optional module – Stereo calling	–
Level versus time noise directivity (similarity)	Optional module – Stereo calling	–
Level versus time during far end speech – comfort noise generation (CNG) directivity (similarity)	Optional module – Stereo calling	–
Stereo pickup directivity (high treble, treble, mid, low), various angles	Optional module – Stereo calling	–

SMD name	Personal speaker-phone	Shared space speaker-phone
EQUEST (Echo MOS) – Far end panned hard right/hard left	Optional module – Stereo calling	Optional module – Positional audio for enhanced meeting room (EMTR)
EQUEST (Echo MOS) – Far end dynamic panning left to right	Optional module – Stereo calling	Optional module – Positional audio for enhanced meeting room (EMTR)
Maximum offset for left vs. right output level difference	–	Optional module – Positional audio for enhanced meeting room (EMTR)
Left vs. right output level difference for balanced render	–	Optional module – Positional audio for enhanced meeting room (EMTR)
Left vs. right frequency response difference for balanced render	–	Optional module – Positional audio for enhanced meeting room (EMTR)
DUT ultrasound render capability	–	Informative measurement
Double talk send activation	Informative measurement	Informative measurement

- Included
- Not included

OPTIONS

Please refer to *Options by use case on page 11* to determine the equipment for customized use cases. The items listed below are options that are independent of the use case.

Hardware

HIS L (Code 1701)

- › Head Impedance Simulator, left, for HMS II.3
- › Only for optional module 'Positional audio for EMTR'

HIS L LN HEC (Code 1701.2)

- › Head Impedance Simulator, left, low-noise, human ear canal version, for HMS II.3 LN HEC
- › Only for optional module 'Positional audio for EMTR'

Software

ACOPT 02 (Code 6812)

- › ACQUA Option Signal Analysis

RELEASE NOTES

Database revision and specification version

Database revision	Based on specification	ACQUA version	labCORE firmware version
Revision 06	Microsoft Teams Audio Test Specification V5.0 including Addendum A	at least ACQUA 6.2.210 ³	at least 3.12.10

³ The MS Teams database is restrictedly applicable with ACQUA 6.0.100. ACQUA 6.0.100 excludes the application of Unicast with Bluetooth LE Audio, and the application of EQUEST according to ETSI TS 103 802. ACQUA 6.2.210 (or newer) in combination with labCORE firmware 3.12.10 (or newer) is required for application of Unicast with Bluetooth LE Audio. ACQUA 6.1.100 (or newer) is required for application of EQUEST according to ETSI TS 103 802.

GENERAL REQUIREMENTS

Please refer to *Requirements by use case on page 10* to determine the equipment for customized use cases. The items listed below are generally required independent of the use case.

Hardware

Hardware Platform

labCORE (Code 7700)

- › Modular multi-channel hardware platform
- coreBUS (Code 7710)
- › labCORE I/O bus mainboard
- coreOUT-Amp2 (Code 7720)
- › labCORE power amplifier board
- coreIN-Mic4 (Code 7730)
- › labCORE microphone input board
- coreBEQ (Code 7740)
- › Binaural equalization for one artificial head

Head and Torso Simulator

One of the following Head Measurement Systems:

HMS II.3 (Code 1703)

- › Head Measurement System, basic version with right ear simulator, 3.3 pinna, and artificial mouth

HMS II.3 LN HEC (Code 1703.2)

- › Head Measurement System, low-noise version with human-like ear canal simulator right and artificial mouth

Additional Equipment

HMT III (Code 1961)

- › Height-adjustable tripod

DSB IV.1⁴ (Code 2408.1)

- › Digital sound board, USB version

1 × Pressure-field microphone

2 × Windows-PC

- › 1 × Microsoft Teams reference client

- › 1 × Microsoft Teams DUT client

Continued on next page

⁴ Testing a DUT (E2E) with a native Bluetooth connection via labCORE (instead of a direct connection to the DUT client) requires a second DSB IV.1 Digital Sound Board.

SCOPE OF DELIVERY

MS Teams (Code 60026)

- › Revision 6
- › delivered as ACQUA database backup

Calibration audio file

- › for Microsoft Teams reference client PC

V2C file

- › License file for ACQUA dongle

MS Teams reference/DUT Editor

- › Available in HEAD acoustics web customer area

2 × HASP USB dongle incl. drivers

- › for Microsoft Teams reference/DUT client PCs

Filter and source file for open loop measurements

- › for ultrasound render capability of the device under test

Revision history

- › PDF file

GENERAL REQUIREMENTS

Software

Control Software

One of the following software applications:

ACQUA (Code 6810)

- › Advanced Communication Quality Analysis Software, full-license version

ACQUA Compact (Code 6860)

- › Compact test system

Background Noise Simulation

One of the following background noise simulation systems:

3PASS *lab* (Code 6990)

- › Background noise simulation system with automated equalization – lab version

HAE-BGN (Code 6971)

- › Background noise simulation system with semi-automated equalization

ACQUA Options

ACOPT 21 (Code 6844)

- › 3QUEST – 3fold Quality Evaluation of Speech in Telecommunication (NB/WB)

ACOPT 29 (Code 6856)

- › EQUEST – Echo Quality Evaluation of Speech in Telecommunication

ACOPT 30-SL⁵ (Code 6876)

- › Option POLQA - Perceptual Objective Listening Quality Analysis (Soft License)

ACOPT 32 (Code 6859)

- › Speech-based Double Talk analysis

⁵ Supersedes ACOPT 30 (Code 6857). An existing ACOPT 30 license is still applicable.

REQUIREMENTS BY USE CASE

Headsets

Use case / Requirement	USB	Wireless (USB dongle)	Bluetooth
Artificial mouth (2nd talker)	Artificial Mouth (according to Recommendation ITU-T P.51), only for certification as an 'Open office headset'		
Headset connection to labCORE	Not required		For Bluetooth Classic: <ul style="list-style-type: none"> > coreBT2 For Bluetooth LE Audio: <ul style="list-style-type: none"> > coreBT2LE-EVO > coreBT2LE-Unicast

Personal Space Desk Phones and Speakerphones

Use case / Requirement	Handset (desk phone)	USB	Wireless (USB dongle)	Bluetooth
Handset positioner	One of the following devices: <ul style="list-style-type: none"> > HHP IV > HHP III.2 	Not required		
Free-field microphone (1/2", IEC 61094-4 compliant)	Not required	Required		
Artificial mouth	Not required	Artificial Mouth (according to Recommendation ITU-T P.51)		
Speakerphone/desk phone connection to labCORE	Not required		For Bluetooth Classic: <ul style="list-style-type: none"> > coreBT2 For Bluetooth LE Audio: <ul style="list-style-type: none"> > coreBT2LE-EVO > coreBT2LE-Unicast 	
Microphone/mouth mount	Not required	PSMM Skype		

Shared Space Speakerphones

Use case / Requirement	USB	Wireless (USB dongle)	Bluetooth
Free-field microphone (1/2", IEC 61094-4 compliant)	Required		
Artificial mouth	Artificial Mouth (according to Recommendation ITU-T P.51)		
Microphone/mouth mount	PSMM Skype		
Speakerphone connection to labCORE	Not required		For Bluetooth Classic: <ul style="list-style-type: none"> > coreBT2 For Bluetooth LE Audio: <ul style="list-style-type: none"> > coreBT2LE-EVO > coreBT2LE-Unicast

Required Products in Detail

coreBT2 (Code 7782)

- › labCORE I/O module, Bluetooth reference access point, version 2

coreBT2LE-EVO (Code 7805)

- › labCORE I/O module, Bluetooth reference access, point version 3, base for Low Energy Audio (LC3)

coreBT2LE-Unicast (Code 7789)

- › labCORE Bluetooth Low Energy Audio (LC3), option Unicast (coreBT2LE module required)

PSMM Skype (Code 6595)

- › Positioning stand for 1/2" microphone and artificial mouth according to MS Teams or Skype Standard

HHP IV (Code 1406)

- › Handset positioner, MotoMount (hexapod) version

HHP III.2 (Code 1430)

- › Handset positioner, VariMount version

OPTIONS BY USE CASE

Headsets

Option \ Use case	USB	Wireless (USB dongle)	Bluetooth
Motorized turntable for turning the HATS wearing the headset	HRT I with SB HRT		

Personal Space Desk Phones and Speakerphones

Option \ Use case	Handset (desk phone)	USB	Wireless (USB dongle)	Bluetooth
Motorized turntable for turning the device under test	Not required	HRT I with TEP-100		
Motorized reflector for variable echo path tests	Not required	HRR I		

Shared Space Speakerphones

Option \ Use case	USB	Wireless (USB dongle)	Bluetooth
Motorized turntable for tuning the device under test	HRT I with TEP-100		
Motorized reflector for variable echo path tests	HRR I		

Optional Products in Detail

HRT I (Code 6498)

- › HEAD acoustics remote-operated turntable

TEP-100 (Code 6499)

- › HRT I turntable expansion plate (100 cm diam., incl. emergency stop push-button)

SB HRT I (Code 6501)

- › Stand base for HMS II.x mounting on HRT I

HRR I (Code 6597)

- › HEAD acoustics rotating reflector (variable acoustic echo path)

IN PRACTICE

APPLICATION EXAMPLES

Measurement of a Personal Speakerphone with MS Teams

This exemplary test scenario depicts testing a personal speakerphone as laid out in the Microsoft Teams test specification. This test is designed to assess the device's performance in a quiet environment and no acoustic reflections (anechoic room). For this test, a dialog with the DUT is simulated with a measurement microphone and a standalone artificial mouth instead of an artificial head. That eliminates unwanted acoustic reflections on head, shoulders, and torso. Measurements with an artificial head are also part of testing speakerphones for assessing their performance in a reverberant environment as well as for other specialized test cases which are part of optional measurement modules.

labCORE connects via the audio interface DSB IV.1 to a PC running a Teams reference client. A second PC runs the Teams client for the device under test (DUT). Both PCs have access to a local network as well as the Internet through a router.

The speakerphone is placed on the motorized turntable HRT I equipped with its mechanical extension TEP-100, simulating a table with 100 cm diameter for the DUT. Rotating the DUT is part of the frequency response tests in an anechoic room as well as of the optional tests of stereo calling performance.

The dedicated stand PSMM Skype carries the measurement microphone and the artificial mouth. ACQUA operates as the central software to generate, receive, and analyze signals.

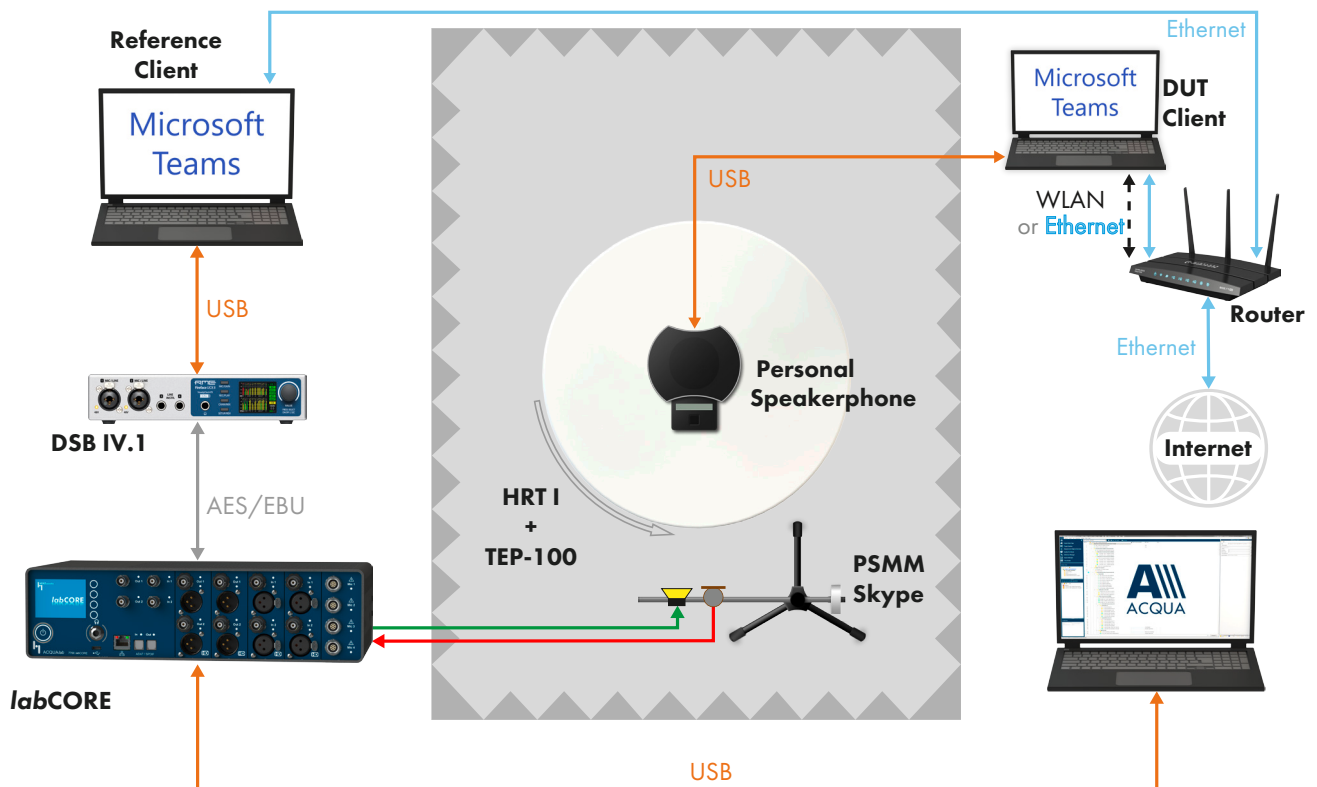

Measurement of a Shared Space Speakerphone with MS Teams

This exemplary test scenario depicts testing a conferencing (shared space) speakerphone unit as laid out in the Microsoft Teams test specification. This test is designed to assess the device's behavior in a real-life situation.

A dialog with the DUT is simulated with HMS II.3. *labCORE* connects via the audio interface DSB IV.1 to a PC running a Teams reference client. A second PC in the test room runs a Teams client for the device under test, connecting via USB. Both PCs have access to a local network as well as the Internet through a router.

The speakerphone is placed on the motorized turntable HRT I equipped with its mechanical extension TEP-100, simulating a table with 100 cm diameter for the DUT. Rotating the DUT is part of the frequency response tests in an anechoic room.

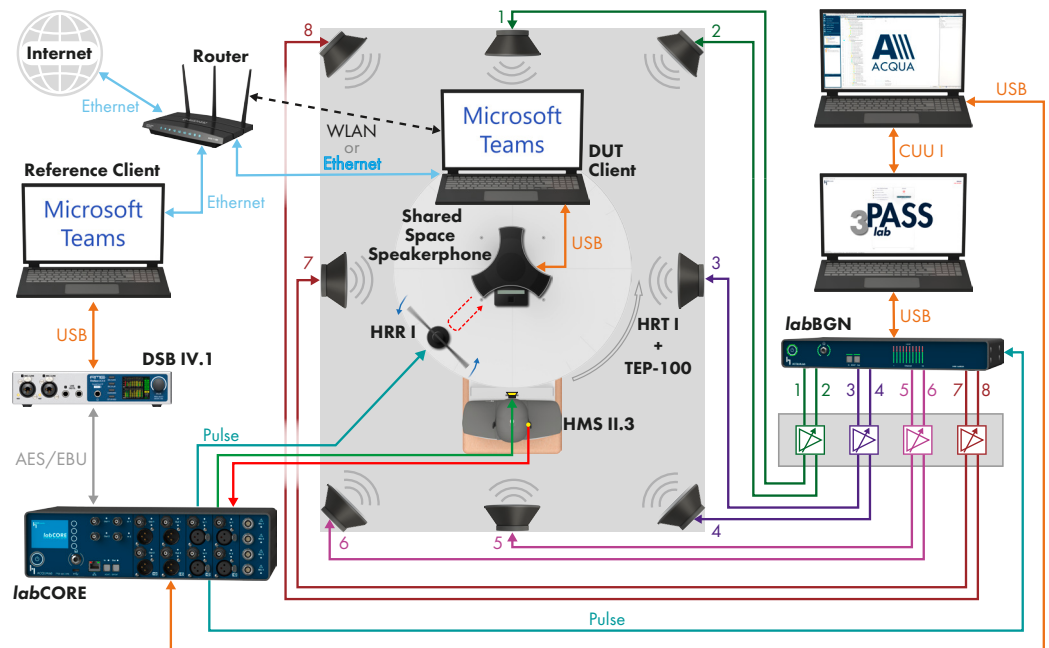

Background noise in this reverberant room is simulated with 3PASS *lab*. ACQUA operates as the central software to generate, receive, and analyze signals.

HRR I provides a rotating reflective surface for generating a variable echo path.

Measurement of a (Native) Bluetooth Headset with MS Teams

This exemplary test scenario depicts testing an over-ear headset with a microphone boom as laid out in the Microsoft Teams

test specification. This test is designed to assess the device's isolated performance by bypassing the regular test setup with client PCs (displayed semi-transparent) and applying a 'device direct' connection via Bluetooth directly to *labCORE*. Other mandatory tests, however, depend on the regular setup, thus the device direct connection cannot replace a full test setup.

A dialog with the DUT is simulated with HMS II.3. *labCORE* connects to the headset via Bluetooth. ACQUA operates as the central software to generate, receive, and analyze signals.

