

Example of convergence test result in ACQUA analysis module ACQUAlyzer. Upper window: Time sequence (green: measured signal, gray: source signal). Lower window: Level vs. time analysis of measured signal referred to source signal (green) and tolerance scheme (gray).

## DESCRIPTION

ITU-T Recommendation G.168 (01/2007) defines objective tests to ensure a minimum level of performance for echo cancellers installed in a network. This recommendation defacto represents an internationally accepted quality standard for echo cancellers. It is therefore imperative that echo cancellers meet the requirements given in this recommendation in order to be suitable for world-wide deployment.

The methods described in ITU-T G.168 are available for use with the HEAD acoustics communication analysis system ACQUA as measurement standard G168. In combination with ACQUA and the measurement front end MFE VI, this standard allows the automated analysis and experimental optimization of echo cancellers according to ITU-T G.168.

*Note: For reasons of simplification the test cases specified in ITU-T G.168 only use test signals like CSS as well as artificial background noise scenarios and thus do not represent realistic test scenarios. However, G.168 explicitly recommends that echo cancellers should be optimized by manufacturers based on the experience of subjective tests or alternatively using advanced quality tests with more realistic test scenarios. For this purpose the quality standard HQS-IP-gateway (Code 6786) is optionally available from HEAD acoustics as an ideal supplement to G168.*

## DATA SHEET

# G168 (Code 6750)

## Measurement Standard

Speech Quality Assessment of Echo Cancellers  
 According to ITU-T Recommendation G.168

## Overview

The objective speech quality assessment of echo cancellers is quite a challenge due to the various kinds of signal processing involved (e.g. adaptive filters and non-linear processors in telephone networks or various speech coders, voice activity detection and other signal processing in VoIP scenarios). G168 is a measurement standard which implements the methods described in ITU-T recommendation G.168 (01/2007).

The tests provided by G168 focus on

- Delay
- Convergence
- Echo
- Double talk performance

For advanced tests of echo cancellers, the quality standard HQS-IP-gateway is recommended in addition to G168 (optional).

For manufacturers G168 provides objective guidelines to optimize their echo cancellers. For administrations and network providers it offers selection criteria to ensure a high quality level.

## APPLICATIONS

- Automated speech quality analysis of echo cancellers
- Experimental development and optimization of echo cancellers with objective evaluation of speech quality

## MEASUREMENTS

The following is a complete list of all measurements included in G168:

### Preparation Measurements

- Delay 'Echo' (round trip, Rx and Tx delay)
- Delay 'Double talk'
- Echo Return Loss

### Measurements according to ITU-T G.168 (01/2007)

- Convergence and residual echo tests
- Convergence test with NLP enabled / NLP disabled (with additional peak measurements)
- Convergence test in the presence of background noise
- Performance under double talk conditions
- Double talk test with low near end levels / with high near end levels
- Double talk test under simulated conversation

- Leak rate test - divergence with lacking activation signal
- Infinite return loss convergence test
- Non-divergence on narrow-band signals
- Stability test
- Non-convergence of echo cancellers on specific ITU-T No. 5, 6 and 7 in-band signalling and continuity check tones (optional)
- Comfort noise test
- Facsimile test during call establishment phase
- Cancellation operation on the calling station side / on the called station side

### Extra Tests

- Double talk test with high near end levels - Individual divergence (NLP enabled)
- Double talk test under simulated conversation - modified double talk signal

### Feature

- All SMDs (single measurement descriptors) can make use of command files for EC control

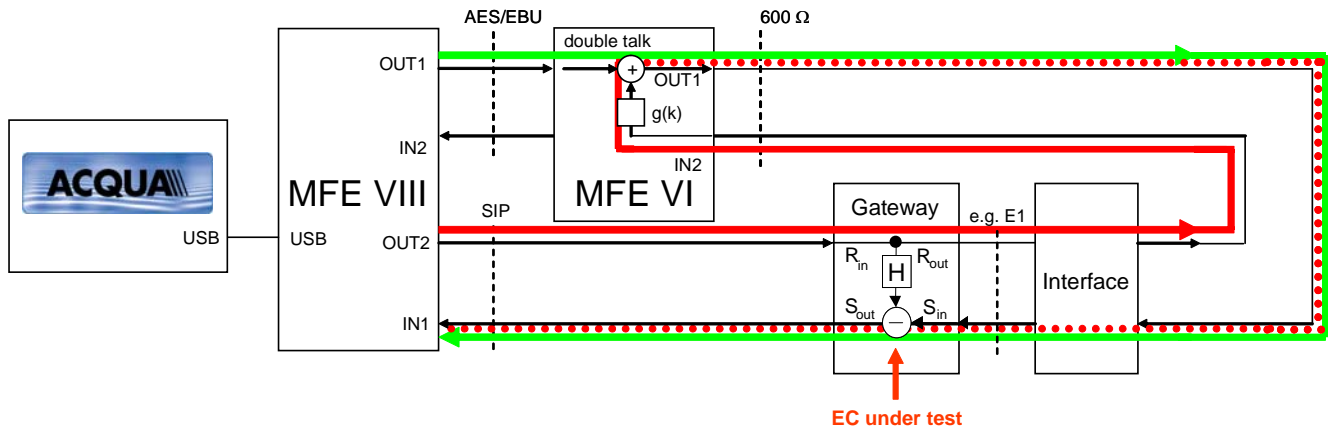

Configuration example for measurement of a gateway echo canceller with analysis system ACQUA and measurement front ends MFE VI and MFE VIII (green: sending direction, red: receiving direction). The echo path simulation  $g(k)$  and feeding of the double talk signal (DT) can be realized either by MFE VI or MFE VIII.

### SYSTEM REQUIREMENTS

**G168** requires the following system components:

- **ACQUA** Advanced Communication Quality Analysis System as one of the following versions (2.4.200 or later):
  - Standard (Code 6810)
  - Standard Workplace (Code 6830, for analysis only)
  - Compact Systems (Code 6860.xx)
- **MFE VI** Analog USB Front End with Level Adjustment (Code 6460)

Optionally, the following components can also be used:

- **MFE VIII** Digital USB Front End with two VoIP Interfaces (Code 6468)
- **MFE IV.3** Digital Front End with two E1/T1 Interfaces (Code 6304)
- **ECC I** Echo Canceller Control (Code 6590)

### DELIVERY

- **G168** (Code 6750), delivered on CD as ACQUA database
- **Keyfile** on CD
- **Manual** as PDF on CD

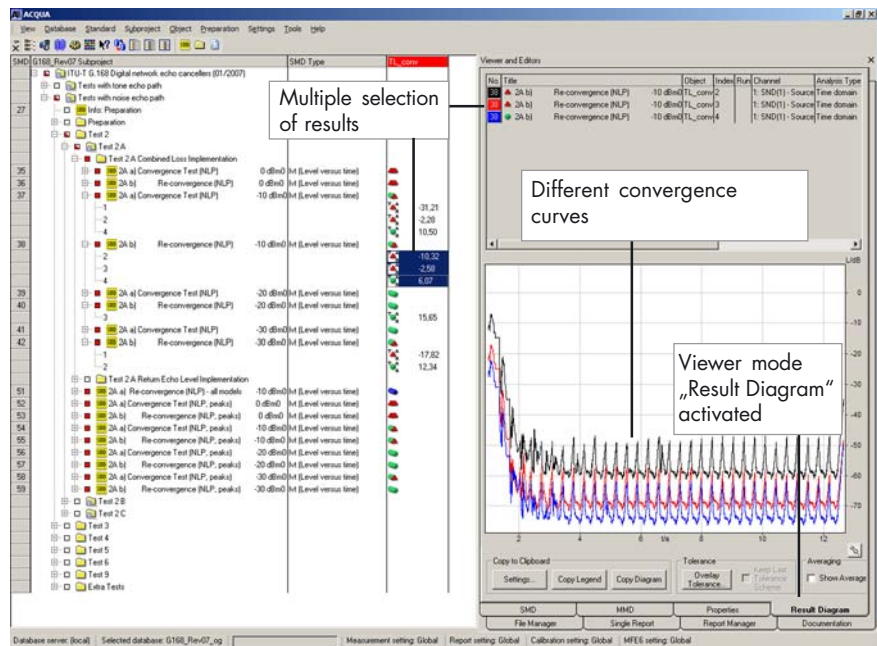

Example of Echo canceller tests with analysis system ACQUA. Several convergence measurements were carried out with the same SMD but with varying echo canceller settings. All resulting curves can be shown in one diagram using the multi-select features and the 'Result Diagram' tab of ACQUA

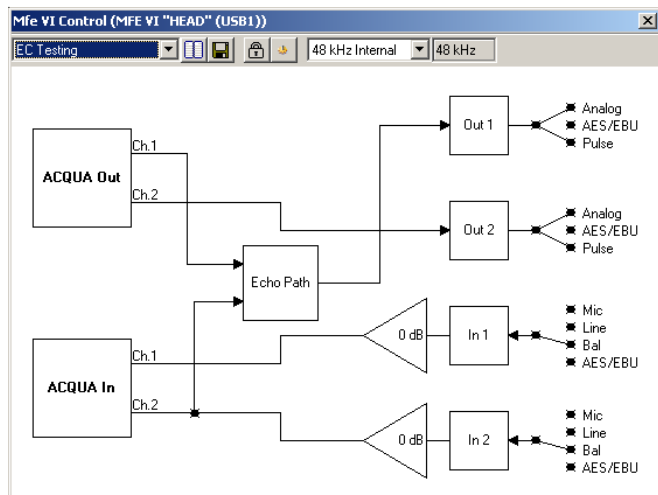

Settings window of MFEVI control in analysis system ACQUA

